

ITEM NO.	DESCRIPTION	QTY.
1	TORQUE WRENCH	1
2	PROTECTIVE CASE	1

CATALOG NUMBER	DESCRIPTION
HBT150750	TORQUE WRENCH

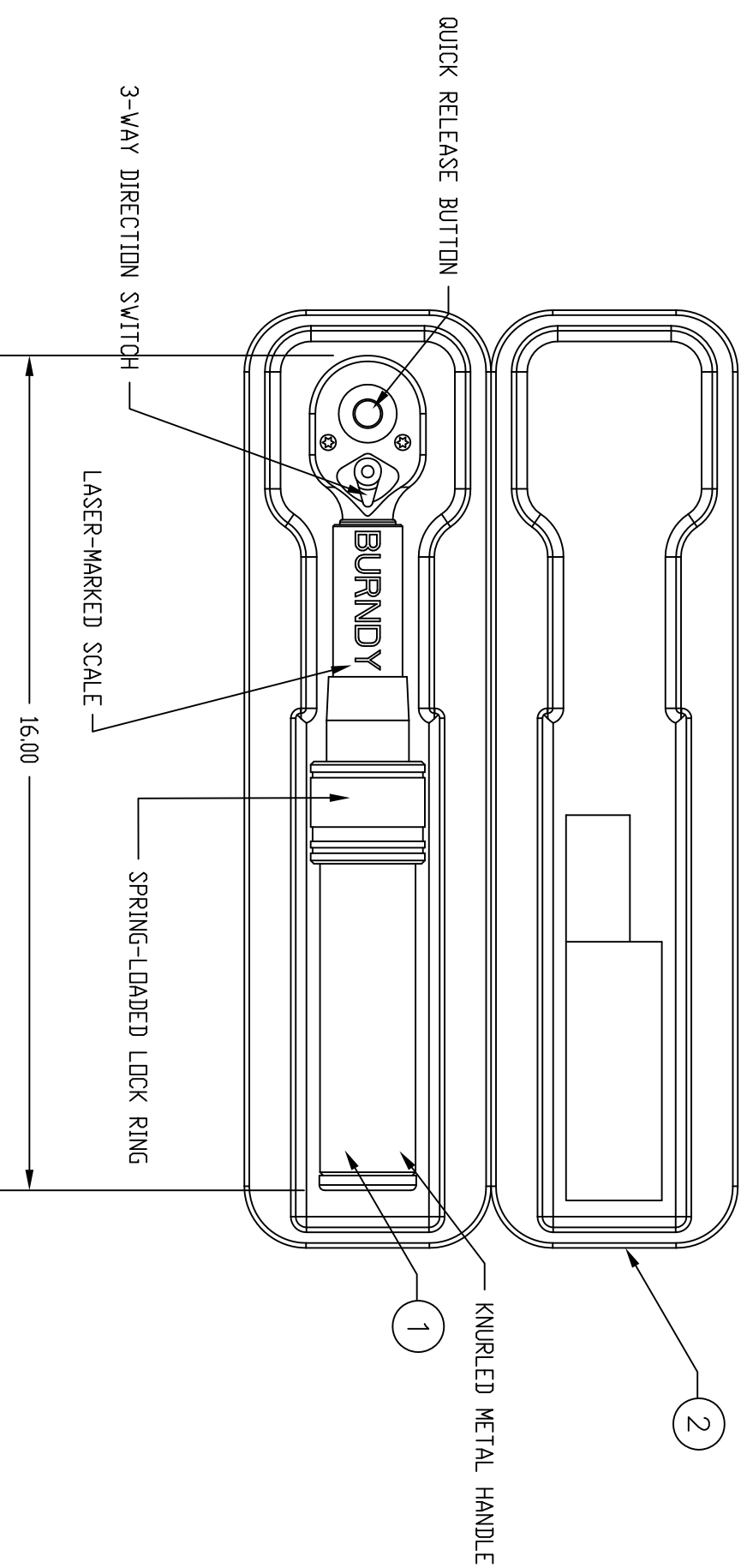

NOTES:

1. SPECIFICATIONS SUBJECT TO CHANGE WITHOUT NOTICE.
2. TORQUE RANGE: 150-750 IN-LB
3. 3/8" DRIVE.

REV.	ECN	DATE	DESCRIPTION	CHG BY	APPD BY
1	17862	2/29/12	INITIAL RELEASE	CG	

Created on AUTOCAD		DIMENSIONING AND TOLERANCE PER ANSI Y14.5M-1982 UNLESS OTHERWISE SPECIFIED, DIMENSIONS ARE IN INCHES (MM). TOLERANCES .XX = ±.01 (.25) .XXX = ±.005 (.127) .XXXX = ±.0025 (.0635) ANGLE TOL ±1°	
PROJECT REFERENCE: 2011-041		MATERIAL: SEE NOTES	
DRAWN BY: C. GRIBBLE 2/29/12		TITLE: 3/8" DRIVE TORQUE WRENCH	
CHECKED BY:		HUBBELL Hubbell Premise Wiring HUBBELL INCORPORATED (Delaware) 14 Lord's Hill Road, Stonington, Connecticut 06378	
APPROVED BY:		SIZE DRAWING NO. B HWS14035C	
SCALE: 1/1		SHEET 1 OF 1	
		REV. 1	